

Production Operations Phase VII



INSERT MATERIAL & DELIVERY SPECIFICATION USING BOWE TURBO 22

VERSION 12
July 2009

IMPORTANT NOTE

Any deviation from this specification must be jointly agreed upon by MBNA Europe Bank Ltd Marketing, CO&F and Production Operations.

Failure to conform to the agreed schedule or material specification will result in the delivery being refused and returned without question.

Contents

Contents.....	2
Introduction.....	3
Insert Testing.....	3
Current Insertion Equipment	3
Recommended Suppliers	3
Acceptable Formats	4
A5 Folding	4
Folded Enclosures.....	5
Single Vertical Folding.....	5
Multiple Vertical Folding	5
Single Horizontal Folding	5
Multiple Horizontal Folding.....	5
Enclosure Specifications	6
Single Sheets	7
Single Sheets from Stacks	7
Single Sheets from Continuous Web	7
Materials Not to be Used for Automated Processing	8
Storage and Preparation of Inserting Material.....	8
Environmental Influences	8
Barcode Specification	9
Visual example of barcode position on 2-page portrait insert	16
Visual example of barcode position on 2-page landscape insert.....	16
Visual example of barcode position on 4-page landscape insert.....	16
Delivery Specification	13
Introduction	13
Delivery Address	13
Booking in Deliveries	13
Delivery Notes	14
Material Returns	14
Stock Presentation	14
Pallet Deliveries.....	15
Packaging and Presentation of Inserts	16
Ram Bundled	16 & 16
Traffic Calming Measures – Map of Phase 7	19
MBNA Delivery Checklist.....	19

Introduction

The following specification provides the basic information required for the production and dispatch to MBNA of advertising material for mechanical insertion through mailing equipment. It also includes important information regarding the packaging, palletisation and shipping of advertising materials used.

MBNA's policy and goals to its customer are firstly to ensure that all advertising material required is enclosed to the highest standard of quality with the correspondence to be mailed and secondly MBNA's commitment to minimise advertising material waste.

In order to achieve these goals, adherence to the guidelines set forth for insert specifications must be consistently upheld and maintained.

Insert Checking

Inserts will be checked on delivery to ensure that they fall within the specifications of this guide. Any inserts outside specification will be immediately escalated and **may not be accepted for insertion.**

Current Insertion Equipment

BOWE Turbo 22 Series

This specification covers insert material for use on the above machine.

Recommended Suppliers

MBNA Europe must ensure that all printers or agencies supplying statement insert material will conform to these requirements. An internal list of all approved MBNA Europe Vendors is available.

Acceptable Formats

We can accept 2, 4, 6 and 8-page A5 inserts, formats and folding requirements as shown below (see page 6 for precise size specification).

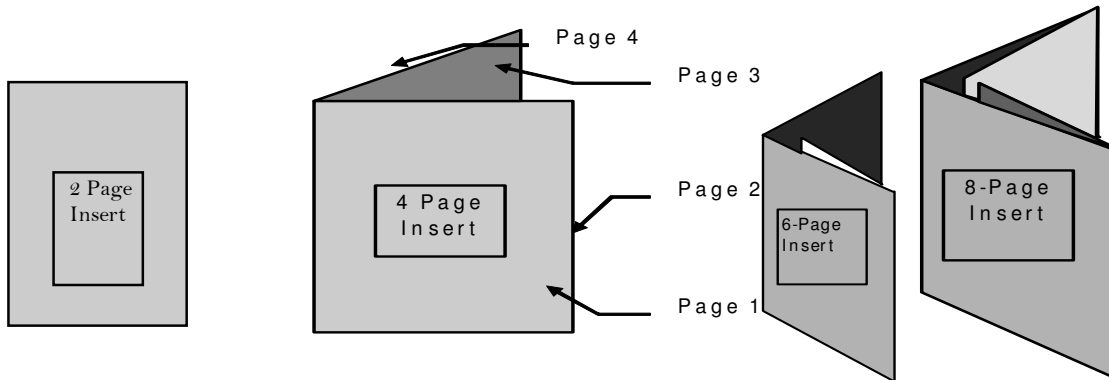

A5 Folding

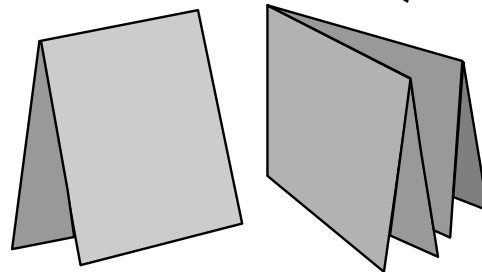
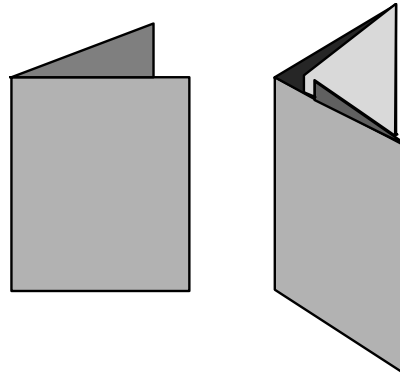

Folded Enclosures

Folded enclosures are most successfully processed when:

- The edges are folded as sharply as possible
- They are not deformed across and/or along the folded edge due to poor storage
- They are folded symmetrically or when folded asymmetrically the folded parts are covering one another

Single Vertical Folding

Enclosures folded vertically should always be folded symmetrically so that they have a uniform thickness over their entire surface.

Multiple Vertical Folding

If the enclosure is to be folded vertically twice or more, the short folded part must always be between the longest folded parts (wrap folded). Some ratios of fold where there is insufficient overlap will lead to feed problems.

Single Horizontal Folding

Enclosures folded once horizontally should always be folded symmetrically so that they have a uniform thickness over their entire surface.

Multiple Horizontal Folding

If the enclosure is to be folded horizontally twice or more then it should be wrap folded.

**** Only evenly folded enclosures will be accepted. Gluing, stitching or stapling is not acceptable****

Enclosure Specifications

The following specifications refer as far as possible to all types of enclosure from single sheet to booklets, etc.

MBNA Specification

A5 is the only acceptable size, two options available as follows:

Option 1:		Option 2:	
Height	210mm	Height	200mm
Width	148mm	Width	145mm

Option 1 is standard size, Option 2 gives another option to maximise print cost savings on larger volumes, should you have the opportunity to do so

Paper Weight (gsm)

2 page	- 110gsm
4, 6 or 8-Page	- 110gsm

Thickness of finished item
Up to 1.8mm

Paper Type
Uncoated Matt Paper

Paper Seal
Unsealed

Enclosure Surface Finish

- All enclosures must be constructed from quality materials with a matt finish
- A static co-efficient of friction (slip factor) of between 0.4 and 0.6
- A dynamic co-efficient of friction (slip factor) of between 0.23 and 0.33
- Consideration must be given to the base paper type, the inks used and final finish to ensure the final product does not stick together
- Enclosures MUST be UV, Air or Air and Infrared dried, or alternately heat set on web printers
- Dusting should be avoided
- Whichever drying process is employed the enclosures must be fully dried.

Single Sheets

Single Sheets from Stacks

Single sheets are often cut from stacks of paper by a plane cutter. This can result in the cut edges felting together and make separation very difficult. If this is the case the sheets must be bent and shaken vigorously until they are separated.

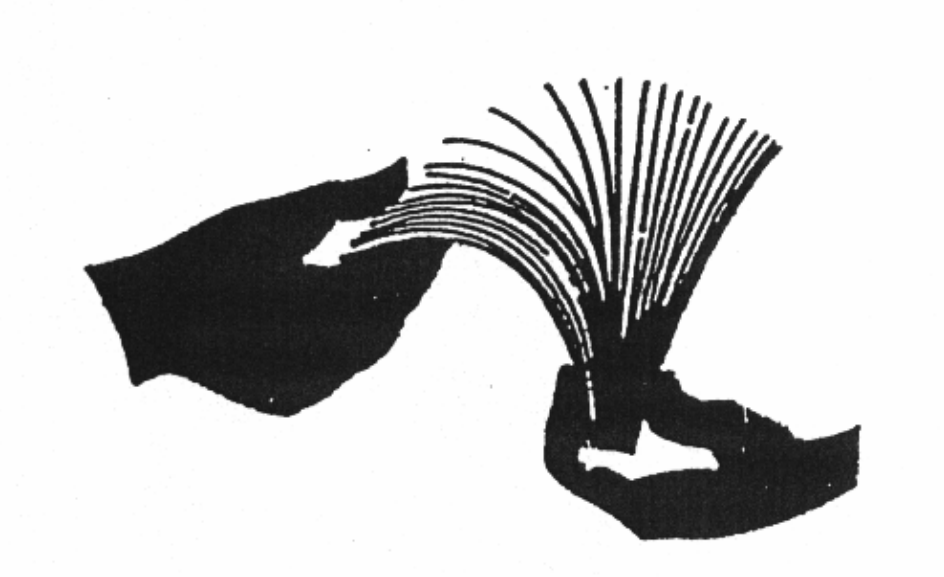

Single Sheets from Continuous Web

Single sheets produced from continuous webs must be strip cut wherever possible, particularly when there is a perforation after each form. There must be no remainders of perforation as these will obstruct or catch during the draw off and/or inserting cycle.

Materials Not to be Used for Automated Processing

- Paper with a high friction factor due to surface structure or sticky printing inks
- Stuck-on applications such as seals, stamps or small samples such as die-cast parts, brooches, coins, etc.
- Multiple, zigzag folded enclosures, vertically or horizontally folded due to their many open edges
- Multiple enclosures folded upon or within one another as these have a tendency to separate either during the draw off or inserting process

Storage and Preparation of Inserting Material

The preparation of all inserting material is extremely important to maximise the system's potential.

Environmental Influences

Storage and mailing conditions at MBNA are set at a temperature of 17 – 22 C and a relative moisture level of 50 – 60%. Severe changes in these values are avoided. All inserting material should be allowed to acclimatise for a period of 8-24 hours before processing.

Barcode Specification

The barcode needs to be to the BOWE specification to ensure the BOWE machines can read them accurately. For third-party inserts, MBNA will supply you with the barcode artwork in both EPS and PDF formats.

EXAMPLE SHOWING LANDSCAPE FORMAT

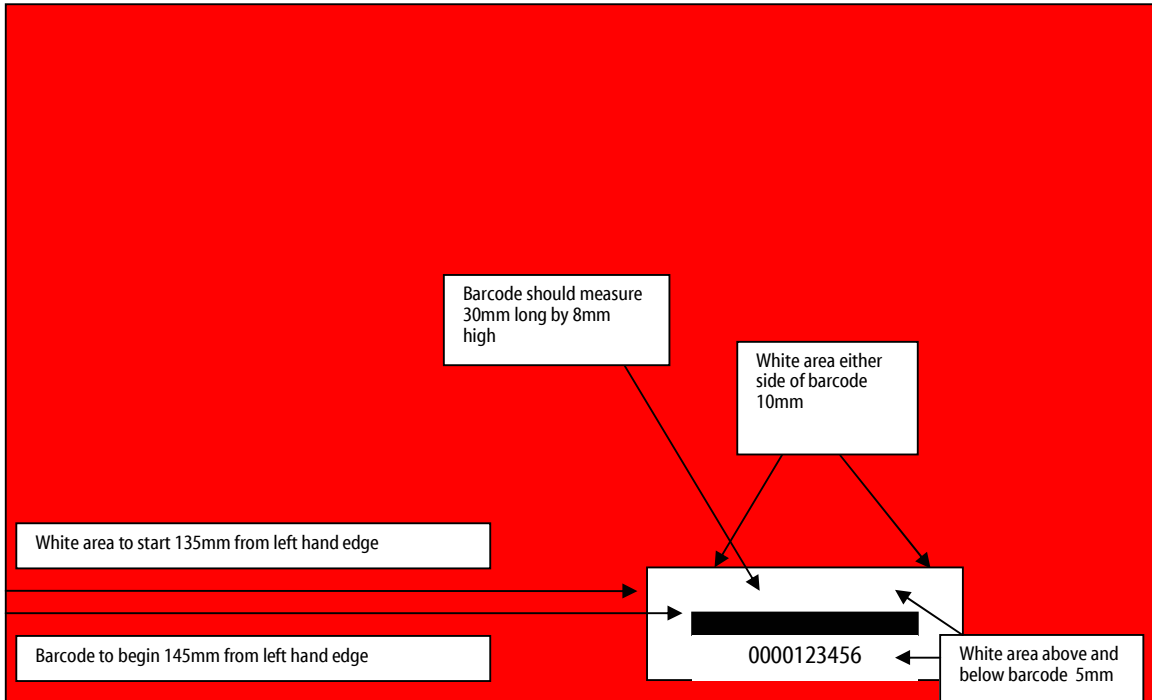

**** Not to scale****

This specification covers all A5 inserts.

- Barcodes should be placed on the bottom right of a landscape format or top right of a portrait format, as follows:
- For inserts where there is a folded edge (i.e. 6 or 8-page inserts), the barcode must be placed on the closed edge to assist with insertion
- The barcode should be right justified Interleave 2 of 5
- Barcodes must be placed in a white box area if being produced on coloured background
- The white area must start 135mm from the left hand edge of the insert (if landscape) and 135mm from bottom of page if portrait.
- There must be a white area of 10mm either side of the barcode (left and right) and 5mm above and below the barcode (top and bottom).
- The actual barcode must start 145mm from the left hand edge of the insert if landscape or 145mm from bottom of page if portrait.
- The barcode must be 30mm in length
- The barcode must be 8mm high
- The 10 digit barcode number must be displayed in the white area below the barcode
- The white area must start 2mm from the bottom edge or right edge of the insert, depending on whether portrait or landscape format.
-

OVERLEAF ARE SOME EXAMPLES OF PRINTED INSERTS SHOWING BARCODE POSITIONS

EXAMPLE OF PORTRAIT FORMAT INSERT – FRONT



EXAMPLE OF PORTRAIT FORMAT INSERT – BACK
Same barcode position required for 2, 4, 6 and 8-page inserts.



EXAMPLE OF 2-PAGE LANDSCAPE FORMAT INSERT – FRONT

CREDIT CARDS
MBNA Points Programme

enjoy

Every time you use your MBNA Rewards Credit Card for retail purchases you'll receive one MBNA Reward Point for every £1 you spend. You can then redeem them for a great range of products and offers.



mbna

EXAMPLE OF 2-PAGE LANDSCAPE FORMAT INSERT – BACK

Enjoy more

Take advantage of your MBNA Reward Points and redeem them for some great products

<p>Kenwood Bar Style Smoothie Maker 5,800 POINTS was 7,700 points</p> 	<p>Bosch 100 Piece Titanium Plus Drill and Screwdriving Set 4,300 POINTS was 5,700 points</p> 
<p>Sony XDRS55 Black DAB/FM Radio 6,700 POINTS was 9,600 points</p> 	<p>Solio Mobile Phone & iPod Solar Charger 7,000 POINTS was 11,700 points (available in black, white or pink)</p> 

Visit www.mbnapoints.co.uk to redeem your Reward Points

MBNA Europe Bank Limited is the operator of the offers. The credit card is issued by MBNA Europe Bank Limited, Registered Office: Stratford House, Christie Road, Park, Chester CH1 5DQ (Registered in England number 2703255. MBNA Europe Bank Limited is authorised by the Financial Services Authority. The subscription value of your points will vary based upon your choice of subscription basis. For more information, please visit www.mbnapoints.co.uk

Mixed Sources
Product groups from well-managed forests and other controlled sources
www.fsc.org Cert no. COC-1234 (UK) 0100
© 1996 Forest Stewardship Council

0000003568

46906_CRM086_02M

EXAMPLE OF 4-PAGE LANDSCAPE FORMAT INSERT – FRONT & BACK

Barcode needs to be on folded edge so in this instance, need to look at the back page as a portrait format and place barcode as shown below

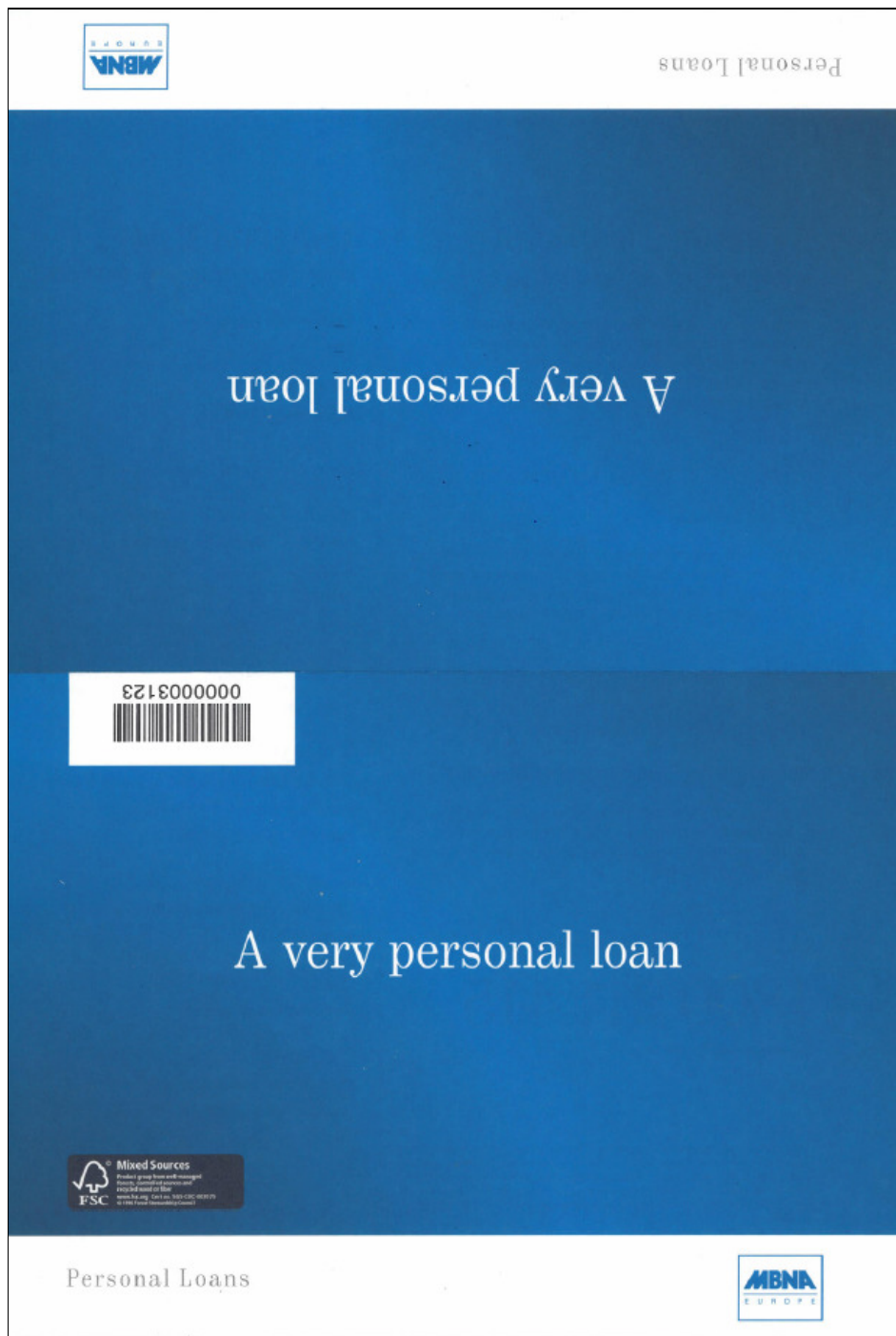

< Fold Line of A5
landscape insert.

Delivery Specification

Introduction

The following specification provides the basic information required for the production and dispatch of material to MBNA. It includes important information regarding the packaging and transporting material used, all of which will provide quality material and reduce waste.

Delivery Address

MBNA Europe Bank Ltd
Phase VII Warehouse
Chester Business Park
Wrexham Road
Chester
CH4 9FB

Booking in Deliveries

All deliveries must be booked-in in advance. Business requirements to deliver materials within 24 hours must be communicated from the ordering department to the Warehouse Manager and the vendor to confirm delivery time.

To obtain a booking in date and time the vendor is to contact the **Warehouse Team on 01244 576431, 01244 576067, or 01244 672344 between 08:00 and 17:00 Monday to Friday.**

All bookings will require the following information:

- Vendor and carrier's name and contact number
- Barcode of each item
- Confirmation of uncoated stock
- Consignment volume i.e. number of pallets, qty per pallet and height of pallet.

When this information has been supplied, a booking reference will be given which is to be quoted on the delivery notes. On arrival the driver must contact Security and give the booking reference from the delivery note using the intercom system at the gate.

Delivery slots are available between 07:30 and 20:00 Monday to Friday. Deliveries outside these times must be arranged via a warehouse Unit Lead and the supplier.

MBNA use the GWL – 2300 Vehicle Restraint system to assist in safe unloading of the contents. Upon arrival the driver and MBNA will jointly assess the vehicle for suitability for this system. Only when both parties have agreed the suitability of the vehicle, is the driver to reverse onto the locking system.

MBNA will not be held responsible for any damage to vehicles using this system.

If there are difficulties in unloading the material due to damage or it not being presented to MBNA in the specification in this document, MBNA will not accept any charges for additional waiting time incurred as a result.

Late/**early** arrivals will be subject to refusal or waiting.

Material should be received as a single delivery vehicle unless the Warehouse Manager or Unit Lead has given prior agreement.

Delivery Notes

A delivery note must accompany all deliveries. The driver of the delivery vehicle should pass this to the warehouse receiving operative.

The delivery note must detail the following:

- Booking in reference
- Vendor's name and contact details
- Barcode of each item
- Number of pallets
- Quantity per pallet
- Quantity per ram

The details on the delivery note must exactly match that shown on the product and pallet labels.

Material Returns

Requests can be initiated verbally on telephone **01244 576431**, **01244 576067**, or **01244 672344** however, verbal requests should still be confirmed by email.

Once a request is received the advised contact will be telephoned to confirm/arrange a mutually convenient collection time.

Should the need arise to escalate an issue concerning a collection, please telephone the business area manager of original order.

Reject material to be collected at no cost to MBNA and removed from site within 5 working days.

Health & Safety

Phase VII delivery area is a high visibility clothing and safety shoe area. Once a driver has reported to a member of the warehouse team, they must return to and remain in the cab of their vehicle.

Stock Presentation

****IN ALL INSTANCES INSERTS MUST ARRIVE ON EURO PALLETS****

**Maximum height of 1.4 metres including pallet must be targeted for every pallet, if volume allows
In order to utilise floor space at MBNA Phase VII, all pallets must target maximum height of 8 Rams,
Any excess rams can be stacked as a Part Pallet - See Figure 1 Page 17**

- Materials must be stored on pallets unless otherwise agreed by the Warehouse Manager
- Deliveries should be transported on fully enclosed vehicles. Flat back lorries with the pallets covered by tarpaulins are not acceptable
- Pallets used for deliveries must be of clean, dry, good quality, in a condition that permits safe handling within health and safety guidelines and prevents damage to materials
- Pallet loads must be stable and secured by 2 pieces of banding in each direction as well as the whole pallet stretched/shrink wrapped
- No stock must overhang the pallet
- One product per pallet
- If the product is batch controlled, one batch per pallet
- Each pallet to have an equal number of ram bundles per layer
- No wood/chipboard allowed to separate layers, or on top of pallets
- Each ram bundle is to be an equal size and contain the same number of single units per pallet
- Any part ram bundles must be clearly marked and placed on the top layer of a pallet
- There is no weight limit for pallets of inserts

Pallet Deliveries

The following must be noted regarding palletised deliveries: -

- MBNA Europe Bank Ltd do not supply pallets
- The cost of the pallet must be included in the material delivery
- No Blue Chep pallets will be accepted

Packaging and Presentation of Inserts

Ram Bundled

It has been proven that the most important aspect of insert preparation for mailing machines is in the way that they are packaged and handled during all stages of the production process.

Special care must be taken to avoid damage to the finished edges. To prevent high wastage levels the following instructions should be adhered to: -

- All inserts must be **Ram Bundled**
- Each Ram Bundle must be marked with material and leaflet quantity in Alpha numerical and barcode. (This should match the delivery note material and quantity barcode)
- All inserts must be facing the same way within the Ram Bundle
- Rubber bands must not be used within a Ram Bundle
- Each Ram Bundle must be in line with ply-board or hard board end pieces
- Cardboard end pieces are not acceptable
- The end pieces should be slightly larger than the insert (1mm all round)
- Plastic strapping should be used in both longitudinal directions. For health and safety reasons, the strapping **MUST NOT** be clear or white
- The maximum weight of each Ram Bundle must not exceed 7kg
- The maximum length of each Ram Bundle should not exceed 280mm

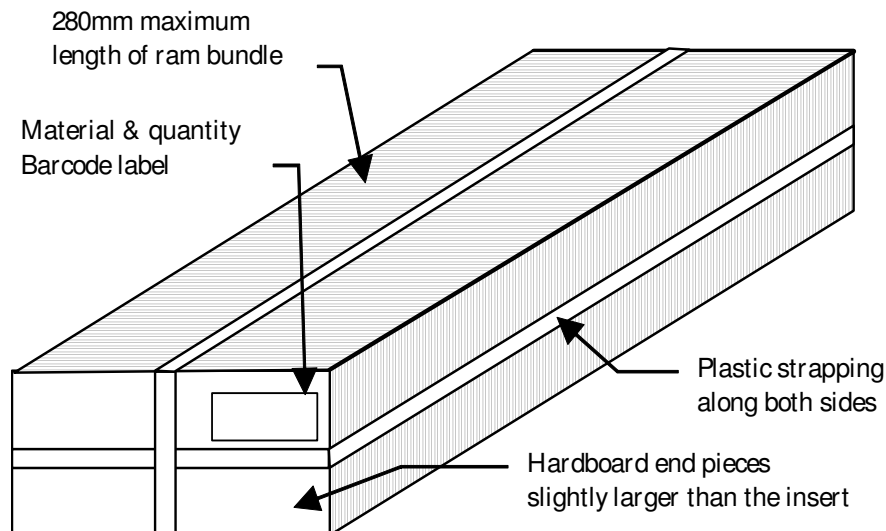

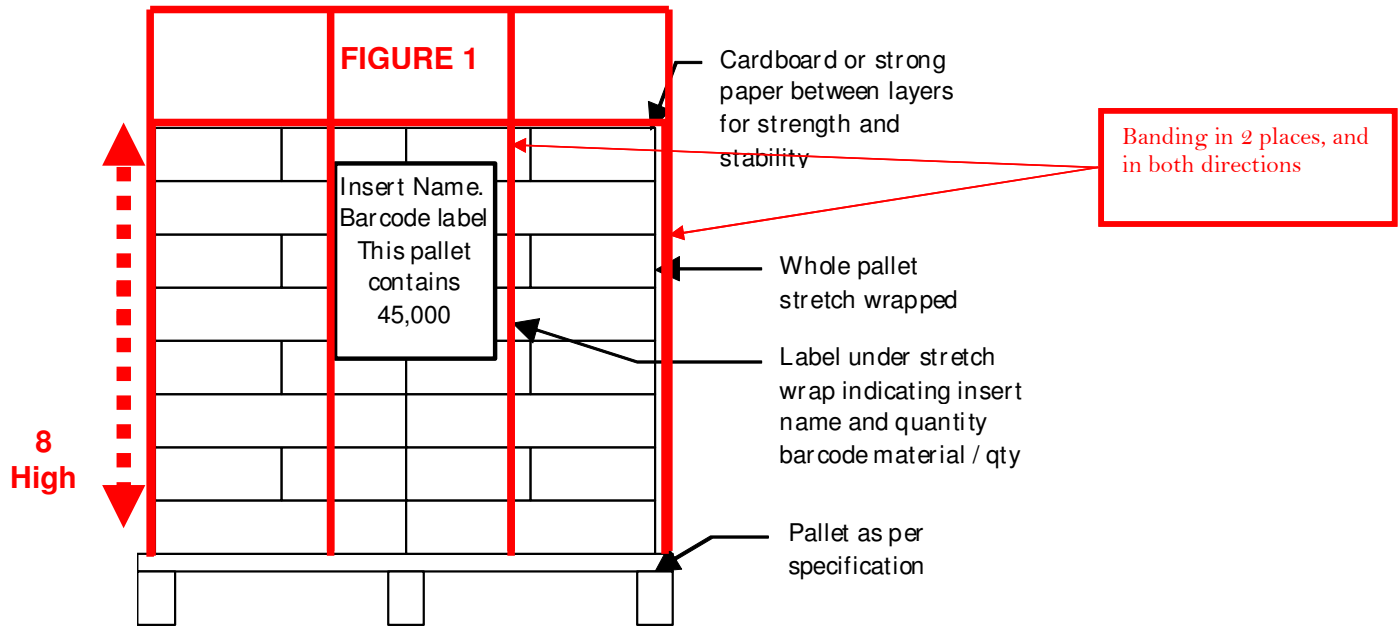

- A sample of the insert or a detailed description should be fixed to the end board
- A note containing the insert name and quantity should be fixed to the pallet under the stretch wrap

Materials should be delivered on Euro pallets only

The pallets, when loaded, should not exceed the following maximums: -

Four way entry pallets

- **Euro pallet 1200mm x 800mm**
- **Height – 1.4 m including pallet**



MAP SHOWING TRAFFIC CALMING MEASURES AROUND MBNA PHASE VII. MAX SPEED LIMIT IS 15 MPH ON ROADS AND 10 MPH IN CAR PARKS.

Vendor Delivery Checklist for MBNA

Booking In Deliveries

To obtain a booking in date and time the vendor is to contact the Warehouse Team on **01244 576431**, **01244 576067**, **01244 672344** or **01244 672600** between 08:00 and 17:00 Monday to Friday

Please ensure that the following information is made available to the person booking in the delivery: -

- Vendor and carrier's name and contact number
- Consignment volume i.e. number of pallets, qty per pallet and height of pallet
- Type of consignment i.e. inserts
- Barcode
- Map is given to the Vendor

Delivery Notes

Please ensure the following information is present on the delivery note: -

- Vendor's name and contact details
- Number of pallets
- Full description of each product
- Barcode number
- Quantity per ram and per pallet

Key Points

- All inserts must be presented in ram-bundles – boxed inserts will be refused delivery
- All inserts must be delivered on Euro Pallets
- Please ensure the quantity per ram/pallet is accurate – quantities will be verified and printers asked to collect and re-supply if they are found to be incorrect
- Arrange inserts on pallets so they reach the maximum of 1.4 meters high (including pallet) providing there is sufficient quantity to do so – on the occasions where excessive pallets are supplied, deliveries will not be accepted
- If inserts are scheduled to arrive more than 2 weeks prior to the date they are due to be fulfilled, the Warehouse MUST be informed